

# PMW-TD300

Solid-State Memory 3D Camcorder

# SONY

make.believe



**XDCM EX**

*Exmor*  
FULL HD 3CMOS

**SXS**





## The First Fully Integrated 3D Shoulder Camcorder from Sony

In response to rapidly growing demand from the 3D production community, Sony proudly introduces the new PMW-TD300 – a professional 3D shoulder camcorder. With its shoulder-mount design, this camcorder has a highly compact body, and provides a stable shooting style that is crucial to creating good 3D images.

Affordable and fully integrated, this 3D camcorder reduces the burden of complicated user adjustments before shooting, such as left- and right-lens alignment. This is a powerful tool to support the rapidly expanding 3D video production industry with an ideal combination of mobility, stability, and affordability.

## » Stable Shoulder Style

The PMW-TD300 shoulder-mount style which has a similar size and weight to current 2D camcorders, and provides a stable shooting style that is crucial for 3D production.

## » Dual Three 1/2-inch Type High Quality Sensors

The PMW-TD300 is equipped with fully integrated dual three 1/2-inch type Exmor CMOS sensors, providing superb low-light sensitivity with an excellent S/N ratio compared to other one-piece 3D camcorders currently on the market. The 1/2-inch type imager size delivers an ideal balance of superior picture performance (with full HD 1920x1080 pixel resolution) and compact body size.

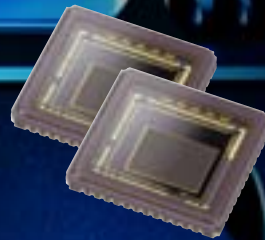

**Exmor**  
FULL HD 3CMOS

## » Manual Control Dial

The lens of the PMW-TD300 adopts a totally new concept with multiple rings on the left side. This unique triple-ring configuration fits comfortably in the user's hand and offers outstanding operability for the Zoom, Focus, and Convergence adjustments. Users can reassign Zoom, Focus, and Convergence on the menu according to personal preference.

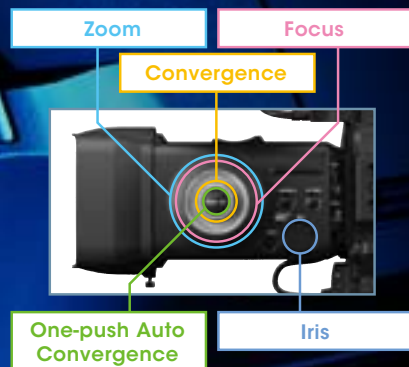

## » Dual Lens System

The newly developed Sony dual lens system is fully synchronized for high accuracy in focusing, zooming, and iris adjustment. This reduces the burden of complicated adjustments before shooting, such as left and right lens alignment.

## » Minimum 3D Shooting Distance of 1.2 m

Due to an incredibly short (45 mm) inter-axial distance, the PMW-TD300 delivers the best shooting zone with the widest range in 3D, easily creating proper 3D imagery even in close proximity to the shooting subject. The minimum distance of the convergence point is 1.2 m, while other one-piece 3D camcorders typically achieve no less than 2.2 m.



Inter-Axial Distance (IAD) 45 mm

## » Convergence Control

The PMW-TD300 enables easy adjustment of the convergence point (the screen plane in 3D images) from 1.2 m to  $\infty$  (parallel). This allows control of the depth effects of shooting objects, using a comfortable, dedicated control dial. The convergence distance can be displayed numerically in meters on the viewfinder.

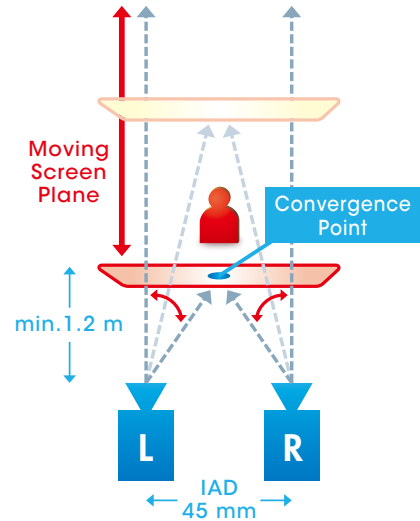

## » One-push Auto Convergence

Another useful feature of the PMW-TD300 is One-push Auto Convergence. This makes the convergence point follow the object in focus instantly, simply by pressing the auto convergence button.

Furthermore, the target convergence point can be pre-set (in a range of -20% to 20%) from the menu.

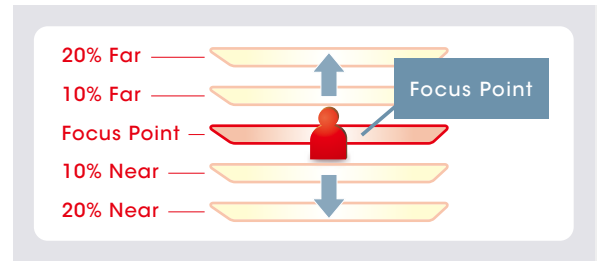

## » Glassless 3D Viewfinder Display

The PMW-TD300 is equipped with a large, easy-to-view, color LCD viewfinder. The viewfinder offers multiple display modes used for convergence adjustment. Additionally, the PMW-TD300 is the first shoulder camcorder equipped with a glassless 3D Xtra Fine LCD™ panel.



**Viewfinder Display Modes**

<div data-bbox="300 1613 571 1755"> <p>L</p> <p>Left only</p> </div>	<div data-bbox="699 1613 970 1755"> <p>R</p> <p>Right only</p> </div>	<div data-bbox="1098 1613 1369 1755"> <p>L+R</p> <p>Mix</p> </div>
<div data-bbox="300 1787 571 1930"> <p>L-R</p> <p>Difference</p> </div>	<div data-bbox="699 1787 970 1930"> <p>Anaglyph</p> <p>Anaglyph(*1)</p> </div>	<div data-bbox="1098 1787 1369 1930"> <p>3D</p> <p>Glassless 3D</p> </div>

(\*1) Not for viewing with anaglyph 3D glasses.

## » 3D Adjustment Assist Features

This professional camcorder has several useful features to assist easy convergence adjustment.



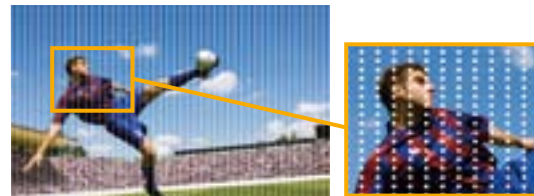
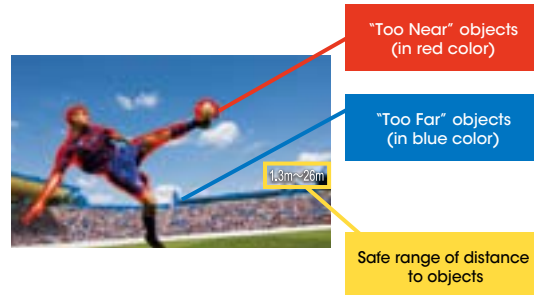

**The Depth Warning Display** feature offers an intuitive graphical display warning, displaying colors on the edge of objects which are out of the appropriate shooting zone in 3D. This threshold level is menu selectable. A numerical display of the safe range of distance to object is also available.

**The Grid Display** feature provides a guide to check L/R disparity in L+R, L-R, and Anaglyph mode on the viewfinder. Grid line width and spacing can also be adjusted on the menu.



## » Various Interfaces

The PMW-TD300 is equipped with a dual HD-SDI output enabling connection with various other professional models, including those which support a 3G HD-SDI interface. HDMI is also provided to monitor the camcorder's video output with consumer 3D displays.

Interface	Mode	Resolution
HD-SDI out (L/R)	Dual (1.5 Gbps x 2)	1920x1080 (L/R) 
	3G (3 Gbps x 1)	1920x1080 (L/R) 
	Side-by-Side (1.5 Gbps x 1)	960x1080 (L/R) 
HDMI out (3D)	Side-by-Side (3D)	960x1080 (L/R) 

This 3D shoulder camcorder offers various remote control interfaces. Numerous camera settings can be remotely controlled using an optional RM or RCP Series Remote Control Unit via its 8-pin remote connector.

The PMW-TD300 is also equipped with lens demand interfaces. In addition to zoom and focus, a newly developed independent convergence remote control interface has been added. Optional lens demands are supplied by third-party vendors. (\*2)

(\*2) Zoom and focus are compatible with Canon demands (analog type).



## » XDCAM EX Recording

This professional camcorder adopts the same recording formats and codec technology as the XDCAM EX Series, offering a proven solid-state workflow for maximum flexibility since most major NLE products offer native support for the XDCAM EX format.

# XDCAM EX

## » SxS Cards Slots

The PMW-TD300 uses SxS memory cards as recording media, just like the rest of the XDCAM EX Series. Left and Right images are recorded onto SxS cards individually in sync, while the two card slots (two each for Left and Right) allow for a long recording time. Over six hours of seamless recording is possible in HQ mode using four 64-GB SxS cards.



# SxS

## » 3D/2D Switchable

With the PMW-TD300, both 3D and 2D shooting are supported. With a single SxS card, the camcorder is able to shoot images only through the left lens. In addition, when recording in 2D operation, it's useful to be able to parallel record onto L/R cards.

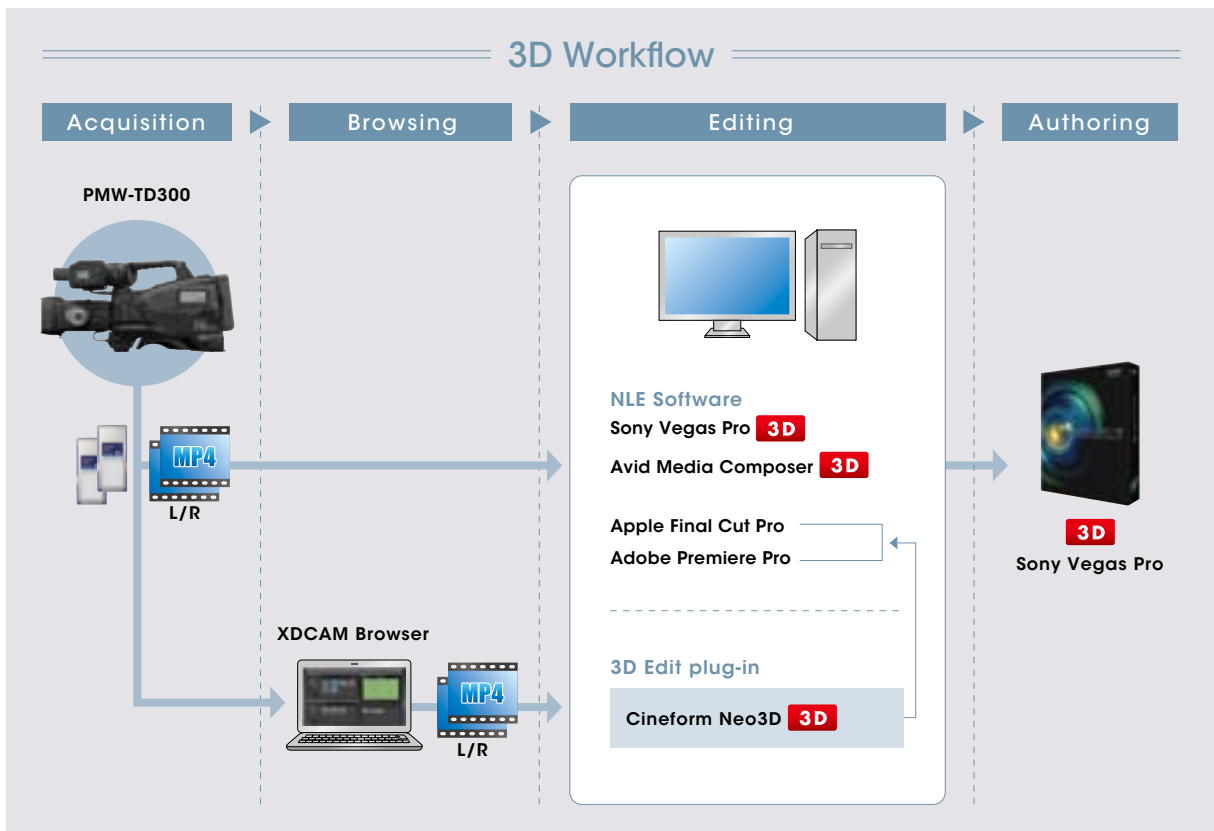

## » System Configuration & Accessories

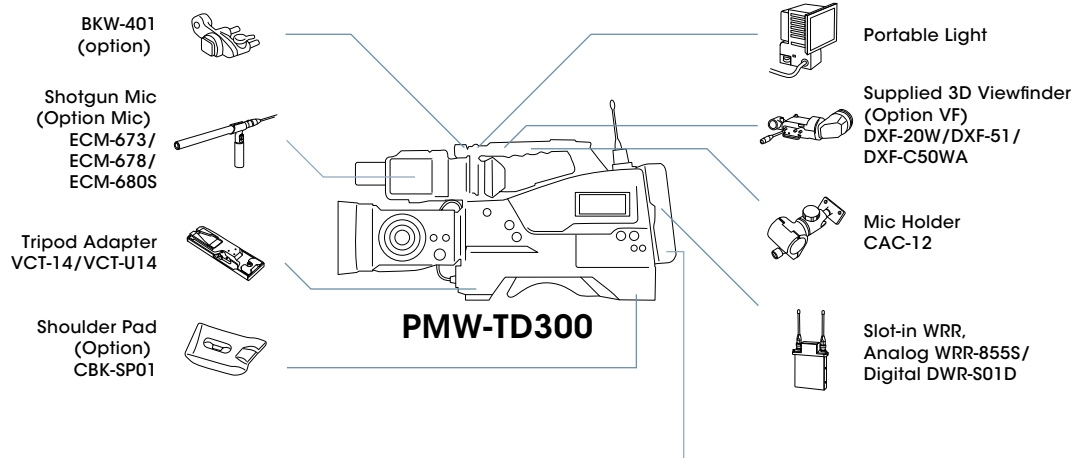

Battery/ AC-Adapter		Li-ion Battery BP-GL95A/GL65A BP-L80S/L60S		Battery Charger BC-L160/L500/L70		AC-DN10/DN2B						
Remote 8pin		RM-B750/B150	RCP-1000/RCP-1001 RCP-1500/RCP-1501 RCP-1530									
Compositior		SD Monitor										
HD/SD SDI		HD Monitor		SD Monitor		XDCAM Decks		XDCAM Station		PMW-EX30		PDW-HR1
HD SDI (L/R)		3D Monitor LMD-4251TD LMD-2451TD		Stereo Image Processor MPE-200 w/ MPES-3D01		SRMASTER Portable Recorder SR-R1 *						
		HD Optical Fiber Unit HDFA-200		3D Switcher DFS-900M MCS-8M								* Expected to be available in 2012
HDMI (3D/2D)		Consumer TV (3D/2D)	USB (Device)		PC		WiFi Adapter CBK-WA01					

Recording Media		SxS Pro		SxS-1		MEAD-MS01 with Memory Stick		MEAD-SD01 with SD Card
-----------------	--	---------	--	-------	--	-----------------------------	--	------------------------

## Specifications

Mass	5.5 kg (12 lb 2 oz) (with viewfinder, mic and lens hood)
Dimensions (W x H x D)	212 x 269 x 489 mm (8.3 x 10.6 x 19.3 inches) without projection (body)
Power requirements	DC 12 V
Power consumption	Approx. 32 W (with viewfinder, lens, and microphone while recording)
Operating temperature	0°C to 40°C (32°F to 104°F)
Storage temperature	-20°C to +60°C (-4°F to +140°F)
Battery operating time	Approx. 170 min with BP-GL95A battery
Recording mode	3D/2D selectable
Recording format (Video)	MPEG-2 Long GOP HQ mode: VBR, maximum bit rate: 35 Mbps, MPEG-2 MP@HL SP mode: CBR, 25 Mbps, MPEG-2 MP@H-14
Recording format (Audio)	LPCM 16 bits, 48 kHz 4 channels
Recording frame rate	HD HQ 1920 Mode: MPEG-2 MP@HL, 35 Mbps/VBR 1920 x 1080/59.94i, 50i, 29.97P, 25P, 23.98P HD HQ 1440 Mode: MPEG-2 MP@HL, 35 Mbps/VBR 1440 x 1080/59.94i, 50i, 29.97P, 25P, 23.98P HD HQ 1280 Mode: MPEG-2 MP@HL, 35 Mbps/VBR 1280 x 720/59.94P, 50P, 29.97P, 25P, 23.98P HD SP 1440 Mode: MPEG-2 MP@H-14, 25 Mbps/CBR 1440 x 1080 /59.94i, 50i (23.98P is converted to 59.94i in 2-3 pulldown processing)
Recording/ Playback time (*1)	HQ Mode: Approx. 200 min with SBS-64G1A (64 GB) memory card Approx. 100 min with SBP-32 / SBS-32G1A (32 GB) memory card Approx. 50 min with SBP-16 (16 GB) memory card SP Mode : Approx. 280 min with SBS-64G1A (64 GB) memory card Approx. 140 min with SBP-32 / SBS-32G1A (32 GB) memory card Approx. 70 min with SBP-16 (16 GB) memory card
Zoom ratio	7x (optical), servo/manual
Focal length	f = 7.5 mm to 52.5 mm (equivalent to 40.6 mm to 284 mm on 35 mm lens)
Iris	F2.6 to F3.4 and Close, auto/manual selectable
Focus	AF/MF selectable, 0.9 m to ∞
IAD (Inter-Axial Distance)	45 mm
Convergence distance	Approx. 1.2 m to ∞
Filter diameter	M105 mm, pitch 1 mm (on lens)
Imaging device	3-chip 1/2-inch type Exmor Full HD CMOS x2
Effective picture elements	1920 x 1080 (H x V)
Optical system	F1.6 prism system

Built-in optical filters	1: Clear, 2: 1/4ND, 3: 1/16ND, 4: 1/64ND
Sensitivity (2000 lx, 3200K, 89.9% reflectance)	F10 (typical) (1920 x 1080/59.94i mode) F11 (typical) (1920 x 1080/50i mode)
Minimum illumination	0.133 lx (typical) (1920 x 1080/59.94i mode, F2.6, +24 dB gain, with 64-frame accumulation)
S/N ratio	54 dB (Y) (typical)
Horizontal resolution	1,000 TV lines or more (1920 x 1080i mode)
Shutter speed	1/60 sec to 1/2,000 sec + ECS(*3)
Slow shutter (SLS)	2, 3, 4, 5, 6, 7, and 8-frame accumulation (3D mode) 2, 3, 4, 5, 6, 7, 8, 16, 32 and 64-frame accumulation (2D mode)
Slow & Quick Motion function	2D mode 720p: Selectable from 1 fps to 60 fps as recording frame rate 1080p: Selectable from 1 fps to 30 fps as recording frame rate 3D mode 720p: Selectable from 17 fps to 60 fps as recording frame rate 1080p: Selectable from 17 fps to 30 fps as recording frame rate
White balance	Preset (3200K), Memory A, Memory B/ATW
Gain	-3, 0, 3, 6, 9, 12, 18, 24 dB
Audio input	XLR-type 3-pin (female) (x2), line/mic/mic +48 V selectable
Video output	BNC (x1), Composite, HD-V
Audio output	XLR-type 5-pin
SDI ( L ) Output	BNC (x1)
SDI ( R ) Output	BNC (x1)
HDMI	Type A 19-pin(x1), output (2D/3D side by side)
Timecode input	BNC (x1)
Timecode output	BNC (x1)
Genlock input	BNC (x1)
USB	USB 2.0 device B Type (x1)
Headphone output	Stereo mini jack (x1)
Speaker output	Monaural
DC input	XLR-type 4-pin
DC output	4-pin
Remote	8-pin
MIC	XLR-type 5-pin
Viewfinder	3.5-inch(*2) type color LCD monitor: approx. 1,230,000 effective pixels 854 (H) x 3 (RGB) x 480(V), 16:9, 2D / 3D view selectable
Built-in LCD monitor	Black & White LCD (Audio Level, TC, battery and media remaining capacity)
Type	ExpressCard/34 slot (x4)

(\*1) Recording/Playback time may vary according to the encoding or memory. (\*2) Viewable area measured diagonally.  
(\*3) Slow Shutter setting frames vary according to the system frequency.

### Distributed by

MK10879V1DNP11SEP

©2011 Sony Corporation. All rights reserved.  
Reproduction in whole or in part without written permission is prohibited.  
Features and specifications are subject to change without notice.  
"SONY", "make.believe", "XDCAM", "XDCAM EX", "SxS",  
"Exmor" and "Vegas" are trademarks of Sony Corporation.  
All other trademarks are the property of their respective owners.

The PMW-TD300 is produced at Sony EMCS  
Corporation's Tokai Technology Center, which  
has received ISO14001, the Environmental  
Management System certification.

